

HLP-C100 quick guide

1. Basic information

This document will guide the customer to complete the basic installation, wiring and functional debugging. If you need more information, please refer to the HLP-C100 manual, download: www.holip.com. The inverter has been tested and packaged strictly before sold. If there is anything abnormal please notify the dealer or the relevant people of our company. For any product questions, please call holip hotline :400-8095-335.

⚠ Danger

Before installing or operating the HLP-C100 inverter, read and understand this manual. The installation, commissioning, repair and maintenance of the inverter must be performed by qualified professional personnel.

- Be sure to turn off the power supply before wiring.
- Even in the case of the main power has been cut off, the internal of the drive may still have residual energy. Before touching input and output terminals, please wait at least 4 minutes.
- Do not plug any connectors of the inverter during the power up to avoid the damage of the inverter or human death. The ground terminal must be grounded correctly.
- R, S, T terminals are power input terminals, never mixed with U.V.W terminals. Be sure that the wiring of the main circuit is correct. Otherwise it will cause damages of the inverter when the power is applied to it.
- If not follow the instructions, it may cause serious injury or death.

2. Dimensions of the inverter

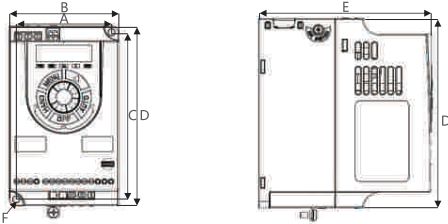

	Power(kW)		A	B	C	D	E	F
1200-240V	3200-240V	3380-480V	mm	mm	mm	mm	mm	mm
0.37-1.5	0.37-1.5	0.75-2.2	74	85	130	140	127	Φ5

3. Installation of the inverter

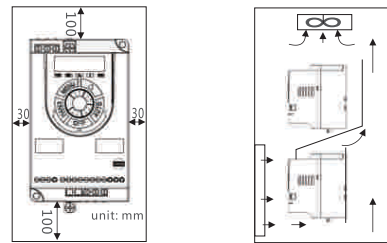

5. Main circuit terminals connection

- ① Connect motor earth wire to earth terminal.
- ② Connect motor to terminals U, V and W.
- ③ To connect a braking resistor, set the braking resistor connected to the terminal + BR -BR
- ④ Connect mains supply earth wire to earth terminal.
- ⑤ Connect mains supply to terminals R, S and T (3-phase) or R and T (single-phase).

6. I/O control terminals connection

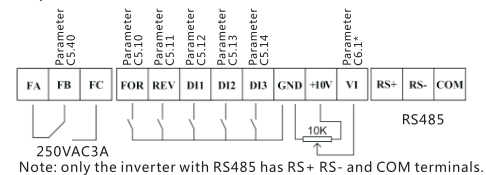

4. Fan disassembly

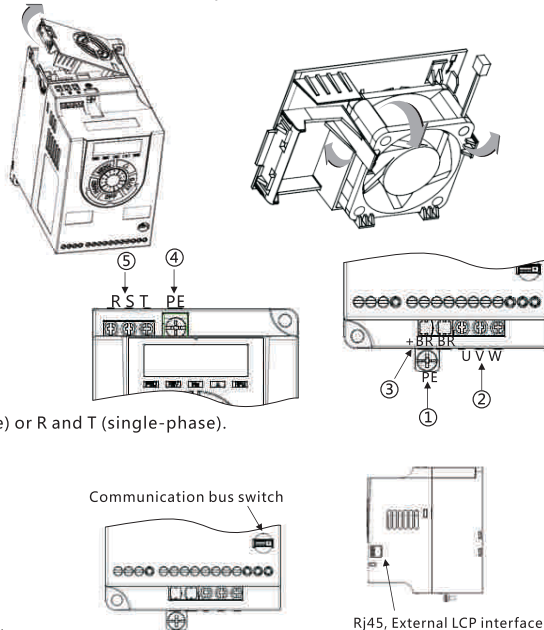

7. LCP Operation

Using LCP to control the inverter [HAND]

Power on the inverter, then press HAND key on LCP, turn the incremental potentiometer to adjust the frequency. Press OFFkey on LCP to stop the inverter.

Key-press	LCP display	Action Description
	F 29.2	turn to adjust the flashing number
	F 29.2	press to shift the flashing number

Using digital input terminals to control the inverter [AUTO]

Power on the inverter, then press AUTO key on LCP. Preset C03.10 or select frequency source by C03.15. C03.16. Connect digital input terminal FOR and GND to start the inverter; Disconnect digital input terminal FOR and GND to stop the inverter;

Set parameters

Example: Set C03.10 [0] =20.5:

Key-press	LCP display	Action Description
	C00.03	Press key to display the first basic C00.03
	C03.03	Turn clockwise to select parameter group C03
	C03.03	Press key to shift to fractional part
	C03.10	Turn clockwise to select parameter C03.10
	[0]	Press to show the first option of C03.10
	000.0	Press to show the value of the first option of parameter C03.10
	000.5	Turn clockwise to change the fractional part to 5
	000.5	Press key to shift to integral part
	020.5	Turn clockwise to change the integral part to 20
	END	Press to accept the change and save it as 20.5

Data Read-outs

Press key to change the display items (reference and currents) on control panel. Set C00.33 can display more items, please refer to HLP-C100 manual.

8. Application cases

Parameter initialization

- Step 1 Set C14.22 = 2
- Step 2 Cut off the main power and Re-power on, LCP displays E.80
- Step 3 Press OFF key on LCP.

C05.11=11, C05.13=14

C06.10=0, C06.11=10, C06.14=0, C06.15=50

Step 4 Press AUTO key on LCP

Forward, Reverse and Jog

Step 1 IO terminals connection

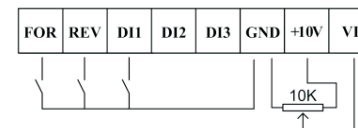

Step 2 Parameter initialization

- Step 3 Set parameter C03.11=10Hz
- C03.15=1, C03.16=0
- C03.41=0.5, C03.42=0.5, C03.80=0.5, C04.10=2

Multi-speed

step 1 IO terminals connection



Step 2 Parameter initialization

Step 3 Set parameter

- C05.10=8, C05.12=15 (Bit0), C05.13=16 (Bit1), C05.13=17 (Bit2)
 C03.10[0]=10 (Speed1=5Hz), C03.10[1]=20 (Speed2=10Hz),
 C03.10[2]=30 (Speed3=15Hz), C03.10[3]=40 (Speed4=20Hz),
 C03.10[4]=50 (Speed5=25Hz), C03.10[5]=60 (Speed6=30Hz),
 C03.10[6]=70 (Speed7=35Hz), C03.10[7]=80 (Speed8=40Hz),

Step 4 Press AUTO key on LCP

PARAMETER GROUP 00: OPERATION/Display	<p>C00.04 Operating State at Power-up [0]Resume ; * [1]Forced stop reference=old ; [2]Forced stop reference=0 ; C00.33 LCP Display Option 0-31 *0 C00.40 HAND key on LCP [0]Disabled ; * [1]Enabled ; C00.41 OFF key on LCP [0]Disable All ; * [1]Enable All ; [2]Enable Reset Only ; C00.42 AUTO key on LCP [0]Disabled ; * [1]Enabled ; C00.60 Menu Password [0]Disabled ; * [1]Enabled ;</p>	BRAKE FUNCTION	<p>[2]AC brake ; C02.11 Brake Resistor (ohm) Dep.on motor date C02.17 Over-voltage Control * [0]Disabled ; [2]Enabled ;</p>	<p>0.10~300.00 * 3.00s C03.90 Ramp 7 Type * [0]Linear ; [2]Sine ramp ; C03.91 Ramp 7 Ramp up Time 0.10~300.00s * 3.00s C03.92 Ramp 6 Ramp Down Time 0.10~300.00 * 3.00s C03.93 Ramp 8 Type * [0]Linear ; [2]Sine ramp ; C03.94 Ramp 8 Ramp up Time 0.10~300.00s * 3.00s C03.95 Ramp 8 Ramp Down Time 0.10~300.00 * 3.00s C03.96 Link preset reference and ramp time * [0]No link ; [1] Link ;</p>	<p>Refer to C05.10 * [10] Reversing ; C05.12 Terminal DI1 Dgital Input Refer to C05.10* [15] Preset ref bit0 ; C05.13 Terminal DI2 Digital Input Refer to C05.10 * [16] Preset ref bit1 ; C05.14 Terminal DI3 Digital Input Refer to C05.10 * [17] Preset ref bit2 ; C05.40 Relay Function (FA-FB, FB-FC) * [5] Drive running ; [9] Alarm ; [10] Alarm or Warning ; [15] Out of frequency rang ; [16] Below frequency, low ; [17] Above frequency, high ; [21] Thermal warning ; [24] Ready, voltage ok ; [25] Reverse ; [26] Bus ok ; [28] Brake, no brake warning ; [53] No alarm ; [55] Running reverse ;</p>	<p>0.10~9999.00s * 999.00s C07.38 Process PI Feed Forward Factor 0~400% * 0% C07.39 On Reference Bandwidth 0~200% * 5% C07.41 Process PI Output Low -100~100% * 0% C07.42 Process PI Output High -100~100% * 100%</p>	<p>* [0] Trip ; [1] Warning ; [2] Disabled ; C14.20 Reset Mode * [0] Manual reset ; [1~10] Automatic reset x 1~10 ; [11] Automatic reset x 15 ; [12] Automatic reset x 20 ; [13] Infinite auto reset ; C14.21 Automatic Restart Time 0~600s * 10s C14.22 Operation Mode * [0] Normal Operation ; [2] Initialisation ; [3] Backup user settings ; [4] Recover user settings ; C14.23 Trip Lock [0] Disable * [1] Enable *C14.51 DC-Link Voltage Compensation * [0] Off ; [1] On ;</p>
PARAMETER GROUP 01: LOAD/MOTOR	<p>C01.00 Configuration Mode * [0] Speed open loop ; [3] Process closed loop ; *C01.20 Motor Power [kW][HP] Dep.on motor date *C01.22 Motor Voltage(Um.n) 50~1000V *C01.23 Motor Frequency (fm.n) 20~400Hz *C01.24 Motor Current(Im.n) Dep.on motor date *C01.25 Motor Nominal Speed (nm.n) 100~9999rpm *C01.42 Motor Cable Length 0~150m C01.55 U/F Characteristic-U 0~999V C01.56 U/F Characteristic-F 0~400Hz C01.71 Start Delay 0.0~10.0s * 0.0s C01.72 Start Function [0] DC hold/delay time ; * [2] Coast/Delay time ; *C01.73 Flying start * [0] Disabled ; [1] Enabled ; C01.80 Function at Stop * [0] Coast ; [1] DC Hold ; C01.82 Min Speed for Function at Stop [Hz] 0.0~400.0Hz * 0.0Hz</p>	PARAMETER GROUP 03: REFERENCE/RAMPs	<p>C03.03 Maximum Reference 0.000~4999.000 * 50.000 C03.07 Actual Reference Calculation Method * [0] Preset reference + Reference1, 2 [1] Preset reference priority C03.10 Preset Reference -100.00~100.00% * 0.00% C03.11 Jog Speed [Hz] 0.0~400.0Hz * 5Hz C03.12 Catch up/slow Down Value 0.00~100.00% * 0.0% C03.15 Reference Resource1 [0] No function * [1] VI [11] Local bus [21] LCP Pot C03.16 Reference Resource2 Please refer to C03.15 * [0] No function C03.18 Relative Scaling Reference Resource Please refer to C03.15 * [0] No function C03.40 Ramp 1 Type * [0] Linear ; [2] Sine ramp ; C03.41 Ramp 1 Ramp up Time 0.10~300.00s * 3.00s C03.42 Ramp 1 Ramp Down Time 0.10~300.00 * 3.00s C03.50 Ramp 2 Type * [0] Linear ; [2] Sine ramp ; C03.51 Ramp 2 Ramp up Time 0.10~300.00s * 3.00s C03.52 Ramp 2 Ramp Down Time 0.10~300.00 * 3.00s C03.60 Ramp 3 Type * [0] Linear ; [2] Sine ramp ; C03.61 Ramp 3 Ramp up Time 0.10~300.00s * 3.00s C03.62 Ramp 3 Ramp Down Time 0.10~300.00 * 3.00s C03.70 Ramp 4 Type * [0] Linear ; [2] Sine ramp ; C03.71 Ramp 4 Ramp up Time 0.10~300.00s * 3.00s C03.72 Ramp 4 Ramp Down Time 0.10~300.00 * 3.00s C03.80 Jog Ramp Time 0.10~300.00 * 3.00s C03.84 Ramp 5 Type * [0] Linear ; [2] Sine ramp ; C03.85 Ramp 5 Ramp up Time 0.10~300.00s * 3.00s C03.86 Ramp 5 Ramp Down Time 0.10~300.00 * 3.00s C03.87 Ramp 6 Type * [0] Linear ; [2] Sine ramp ; C03.88 Ramp 6 Ramp up Time 0.10~300.00s * 3.00s C03.89 Ramp 6 Ramp Down Time</p>	<p>*C04.10 Motor Speed Direction [0] Clockwise ; [1] Counter clockwise ; * [2] Both ; *C04.12 Motor Speed Low Limit [Hz] 0.0~400.0Hz * 0.0Hz *C04.14 Motor Speed High Limit [Hz] 0.0~400.0Hz * 65.0Hz C04.18 Current Limit 0~300% * 150% *C04.19 Max. Output Frequency 0.0~400.0Hz * 65.0Hz C04.52 Warning Speed Low 0.0~400.0Hz * 0.0Hz C04.53 Warning Speed High 0.0~400.0Hz * 65.0Hz *C04.58 Missing Motor Phase Function [0] Off ; * [1] On ; C04.61 Bypass Speed From [Hz] 0.0~400.0Hz * 0.0Hz C04.63 Bypass Speed To [Hz] 0.0~400.0Hz * 0.0Hz</p>	<p>C06.10 Terminal VI Low Voltage 0.00~9.99V * 0.07V C06.11 Terminal VI High Voltage 0.10~10.00V * 10.00V C06.12 Terminal VI Low Current 0.00~19.99mA * 0.14mA C06.13 Terminal VI High current 0.01~20.00mA * 20.00mA C06.14 Terminal VI Low Ref./Feedb.Value -4999.000~4999.000 * 0.000 C06.15 Terminal VI High Ref./Feedb.Value -4999.000~4999.000 * 50.000 C06.16 Terminal VI Filter Time Contant 0.01~10.00s * 0.01s C06.18 Terminal VI Zero dead band 0.00~20.00 * 0.00V/mA C06.19 Terminal VI Mode * [0] Voltage mode ; [1] Current mode ; C06.81 LCP Pot Low Ref. -4999.0~4999.0 * 0.0 C06.82 LCP Pot High Ref. -4999.0~4999.0 * 50.0</p>	<p>C08.01 Control Site * [0] Digital and ctrl.word ; [1] Digital only ; [2] Control Word only ; C08.02 Control Word Source [0] None ; * [1] : FC RS485 ; C08.03 Control Word Timeout Time 0.1~6500.0s * 1.0s C08.04 Control Word Timeout Function * [0] Off ; [1] Freeze output ; [2] Stop ; [3] Jogging ; [4] Max. speed ; [5] Stop and trip ; C08.06 Reset Control Word Timeout * [0] No Function ; [1] Do Reset ; C08.31 Address 1~247 C08.32 Port Baud Rate [0] 2400 ; [1] 4800 ; * [2] 9600 ; [3] 19200 ; [4] 38400 ; C08.33 FC Port Parity * [0] Even Parity, 1 Stop bit ; [1] Odd Parity, 1 Stop bit ; [2] No Parity, 1 Stop bit ; [3] No Parity, 2 Stop bits ; C08.35 Minimum Response Delay 0.001~0.500s * 0.010s C08.36 Max. Response Delay 0.010~10.000s * 5.000s C08.94 Bus Feedback -32768~32767 * 0</p>	<p>PARAMETER GROUP 14: SPECIAL FUNCTIONS</p> <p>PARAMETER GROUP 15: DRIVE INFORMATION</p> <p>PARAMETER GROUP 16: DATA READOUTS</p>
PARAMETER GROUP 02:	<p>C02.00 DC Hold Current 0~150% * 50% C02.01 DC Brake Current 0~150% * 50% C02.02 DC Braking Time 0.0~60.0s * 10s C02.04 DC Brake Cut In Frequency 0.0~400.0Hz * 0.0Hz C02.10 Brake Function * [0] Off ; [1] Resistor brake ;</p>	PARAMETER GROUP 04: LIMITS/WARNIN	<p>C05.10 Terminal FOR Digital Input [0] No operation ; [1] Reset ; [2] Coast inverse ; [5] DC-brake inverse ; [6] Stop inverse ; * [8] Start ; [10] Reversing ; [11] Start reversing ; [14] Jog ; [15] Preset ref bit0 ; [16] Preset ref bit1 ; [17] Preset ref bit2 ; [28] Catch up ; [29] Slow down ; [34] Ramp bit0 ; [35] Ramp bit1 ; [36] Ramp bit2 ; C05.11 Terminal REV Digital Input</p>	<p>PARAMETER GROUP 06: ANALOG IN/OUT</p> <p>PARAMETER GROUP 07:</p>	<p>C07.20 Process CL Feedback Resource * [0] No function ; [15] Preset input VI ; [11] Local bus ref ; C07.31 Process PI Anti Windup [0] Disabled ; * [1] Enabled ; C07.33 Process PI Proportional Gain 0.0~10.00 * 0.01 C07.34 Process PI Integral time</p>	<p>C14.01 Switching Frequency [2~6]: 2kHz~6kHz ; [7] 8kHz ; [8] 10 kHz ; [9] 12kHz ; [10] 16kHz ; * [5] *C14.03 Over modulation [0] Off ; * [1] On ; C14.08 Damping Gain Factor 0~200% * 96% C14.12 Function at Mains Imbalance</p>	<p>PARAMETER GROUP 05: DIGITAL IN/OUT</p>